

# a Giant Pandas b

Quilt by Deb Mosa

Finished Quilt Approximately: 62" x 74"

**Giant Pandas** fabrics by Exclusively Quilters - Style #3694

**Fabric Requirements:** Based on 44" wide fabric

One giant panda panel (#8541-1)

1-7/8 yards dark green (#8549-6)

2/3 yard packed pandas (#8544-8)

1-5/8 yards black fur (#8550-80)

1/4 yard red bamboo leaf (#8578-1)

1 yard red floral (#8547-1)

1/2 yard red fur (#8550-1)

3/4 yard light green (#8578-6)

4-1/2 yards fabric for backing (#8544-8 packed pandas suggested)

*3-7/8 yards fabric for backing if using a non-directional fabric*

68" x 80" quilt batting

template plastic

**Make Template:** Each template is divided into two to six pieces so they will fit on the page. Long dotted lines indicate where the pieces come together. Short dotted lines indicate seam allowances. A small graphic of each template is given to show how it is put together and the finished size of the template is also listed. Trace templates onto template plastic. Cut out and label.

**Cutting Directions:** All measurements based on a 1/4" seam allowance.

From **dark green** fabric cut:

Nineteen 2-1/2" x 44" strips for borders/binding

Two 5-1/2" x 44" strips

From **packed panda** fabric cut:

Three 6-1/2" x 44" strips

From **black fur** fabric cut:

Twelve 2-1/2" x 44" strips for borders

Six 3-1/2" x 44" strip

From **red bamboo leaf** fabric cut:

One 6-1/2" x 44" strip recut into four 6-1/2" squares

From **red floral** fabric cut:

Four 7-1/2" x 44" strips

From **red fur** fabric cut:

Four 3-1/2" x 44" strips

From **light green** fabric cut:

Four 5-1/2" x 44" strips

**Quilt Center:**

1. Trim the panda panel to 18-1/2" x 20-1/2", about 1/2" beyond the red border.

2. Stitch a 3-1/2" x 44" black fur strip to right and left sides of panel. Press and trim excess from these and all successive border additions.

3. Sew a 2-1/2" x 44" black fur strip to top and bottom of panel. Press and trim.

4. Stitch a 2-1/2" x 44" dark green strip to right and left sides, then to the top and bottom.

# Giant Pandas

Page 2

## Pieced Borders:

1. From each of the four 5-1/2" x 44" light green strips, cut a 5-1/2" square and then a **Template A**

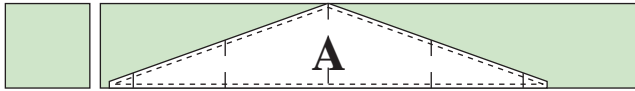

2. From the 5-1/2" dark green strips cut four **Template B** and four **Reverse Template B**.



3. Lay out one light green **A**, one dark green **B** and one **Reverse B**.

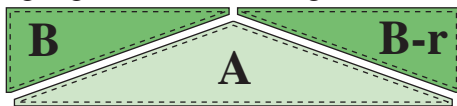

4. It is important that you use care when piecing the large pieced borders.

Fold the **B** piece right sides together with the **A** piece. Line up the seam allowances so the ends of the seams match - even if the ends of the fabric don't match. Use caution when sewing these edges cut along the bias so they don't stretch.

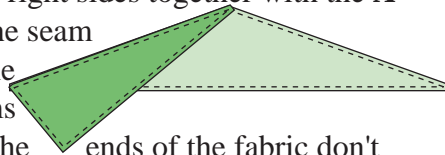

5. Make a total of four pieced green borders - they should measure 5-1/2" x 28-1/2".

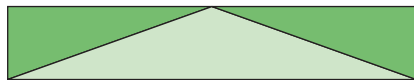

6. Add a green pieced border to right and left sides of quilt. Stitch a 5-1/2" light green square on each end of the two remaining borders then add them to the top and bottom.

7. Sew a 2-1/2" x 44" black fur strip to right and left sides, then to top and bottom of quilt.

8. From each 7-1/2" x 44" red floral strip cut one diamond with **Template C** and two triangles with **Template D**.

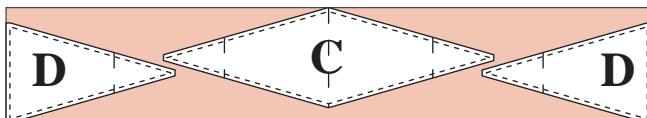

9. Cut two **Template E** pieces from each of four red fur and four black fur 3-1/2" x 44" strips.



10. Lay out a pieced red border as shown. Stitch the pieces into diagonal rows then sew the rows together for 6-1/2" x 42-1/2" borders. Use the seam points as instructed with the green borders.



11. Add a pieced red border to right and left sides. Sew a 6-1/2" red bamboo square to corners of remaining borders then add to top and bottom of quilt.

## Final Border:

1. Cut two 2-1/2" x 44" black fur strips each into two equal halves. Sew each half end-to-end with a full-length strip. Add borders to right and left sides then to the top and bottom.

2. Cut one 6-1/2" x 44" packed pandas strip into two equal halves. Sew each half end-to-end with a full-length strip. Add to the top and bottom of quilt.

3. Make four dark green borders each with two 2-1/2" x 44" strips sewn together end-to-end. Add borders to the right and left sides then to the top and bottom of quilt.

## Finishing:

1. Cut backing into two equal lengths. Sew the two lengths together along selvage edges. Layer the backing, batting and quilt top. Quilt or tie as desired.

2. Prepare binding from seven 2-1/2" x 44" strips of dark green. Sew strips together into one long binding strip. Press strip in half lengthwise.

(continued on page 5)

# Giant Pandas

Page 3

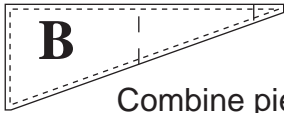

**B**

Combine pieces as shown to create the complete template.

## Template B

5-1/2" x 14-1/2"

This box is 2" square. Measure the box. If it is not 2" square, reduce or enlarge the entire page of templates until it is.

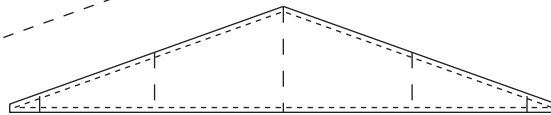
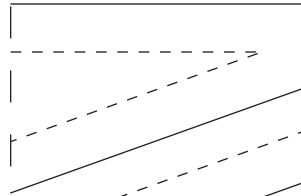

Combine pieces as shown to create the complete template.

## Template A

5-1/2" x 28-1/2"

Trace templates onto template plastic. Cut out each shape and label.

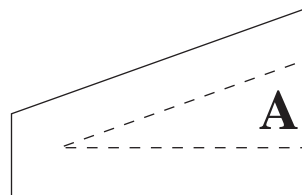

**A**

# Giant Pandas

Page 4



Combine pieces as shown to create the complete template.

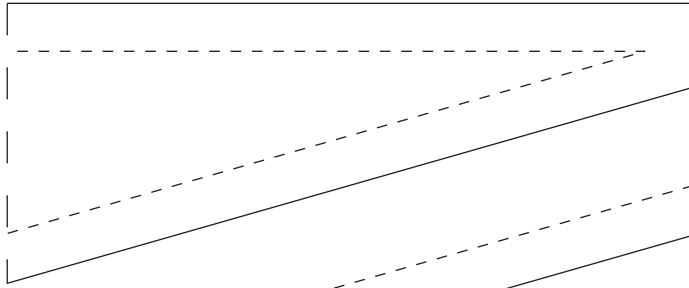

**Template E**  
3-1/2" x 21-1/2"

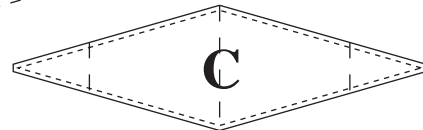

Combine pieces as shown to create the complete template.

**Template C**  
6-1/2" x 21-1/2"

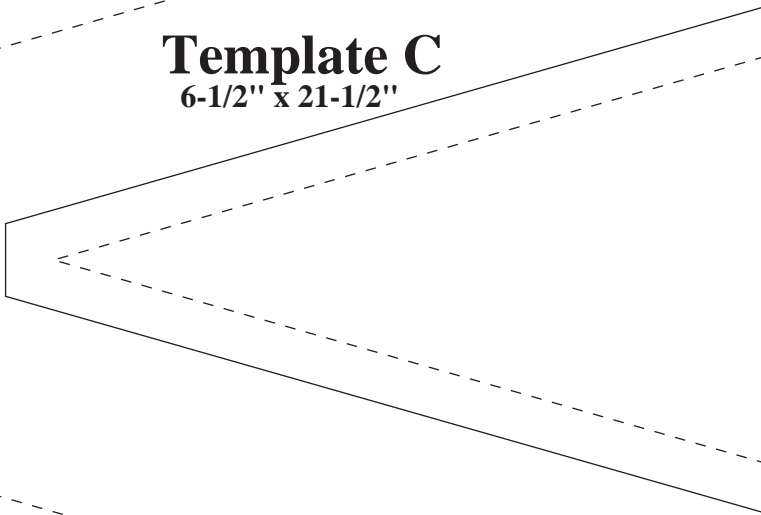

This box is 2" square.  
Measure the box. If it is  
not 2" square, reduce or  
enlarge the entire page  
of templates until it is.

**Trace templates onto  
template plastic. Cut out  
each shape and label.**

# Giant Pandas

Page 5

3. Leaving an 8" tail of binding, sew binding to top of quilt through all layers matching all raw edges. Miter corners. Stop approximately 12" from where you started. Lay both loose ends of binding flat along quilt edge. Where these two loose ends meet, fold them back on themselves and press to form a crease. Using this crease as your stitching line, sew the two open ends of the binding together right sides together. Trim seam to 1/4" and press open. Finish sewing tape to quilt.
4. Turn binding to back of quilt and blind stitch in place.

This box is 2" square. Measure the box. If it is not 2" square, reduce or enlarge the entire page of templates until it is.



Combine pieces as shown to create the complete template.

## Template D

6-1/2" x 11"

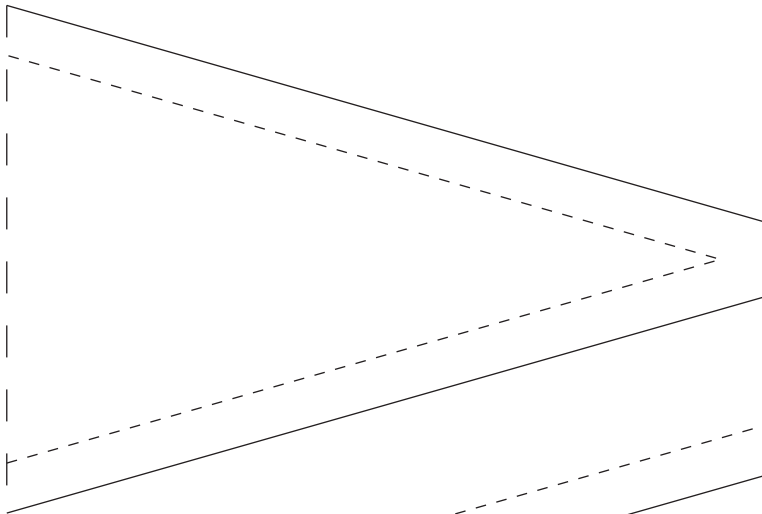

Trace templates onto template plastic. Cut out each shape and label.